

SITUACIJA

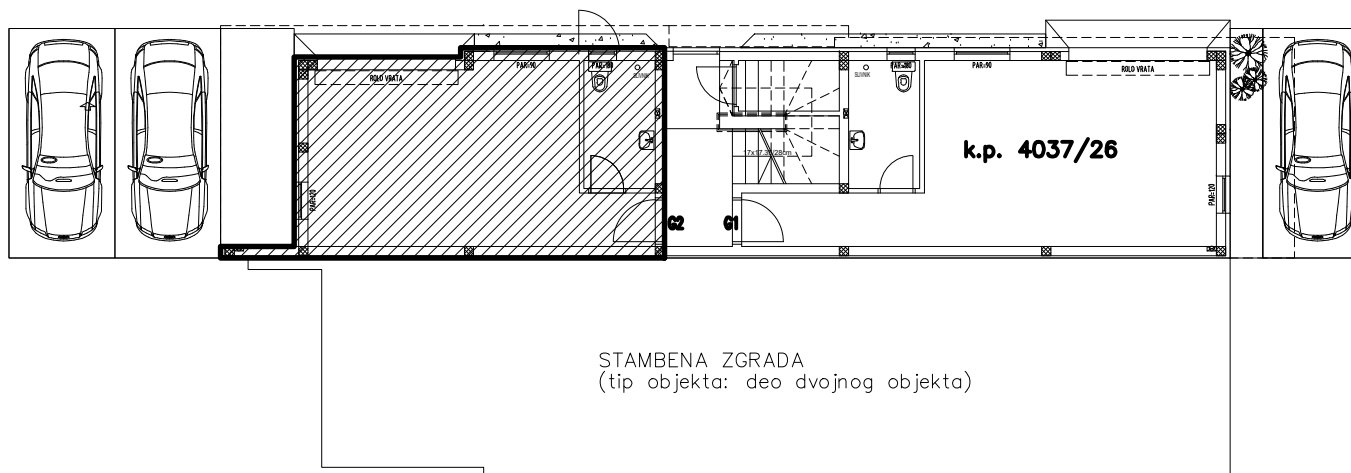

Ulica Dragana Nikolića

GARAŽA 2

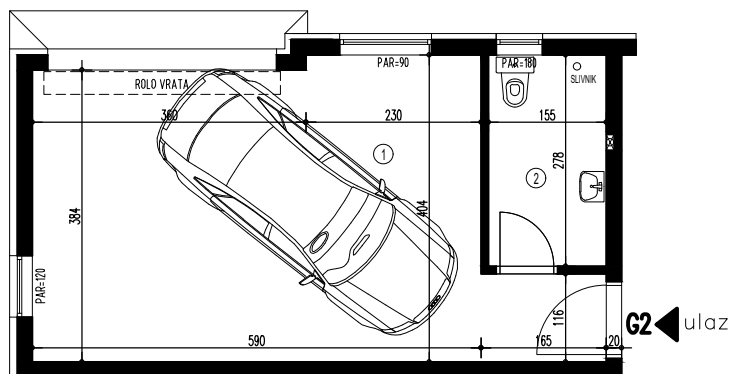

PRIZEMLJE

G2 - garaža

BR.	NAZIV PROSTORIJE	VRSTA PODA	POVRŠINA PODA	KOEF.	KORISNA POVRŠINA
1	Garaža	ker. pločice	25.16 m ²	1.00	25.16 m ²
2	WC	ker. pločice	4.30 m ²	1.00	4.30 m ²
UKUPNO:					29.46 m ²
komercijalna površina				k-0,97:	28.58 m²

BROJ UGOVORA

kontakt tel.